



## EXCAVATOR BUCKET INSPECTION CHECK LIST

Required information

Customer \_\_\_\_\_  
 Machine \_\_\_\_\_  
 Plant no. \_\_\_\_\_  
 Technician \_\_\_\_\_  
 Date \_\_\_\_\_

Additional information

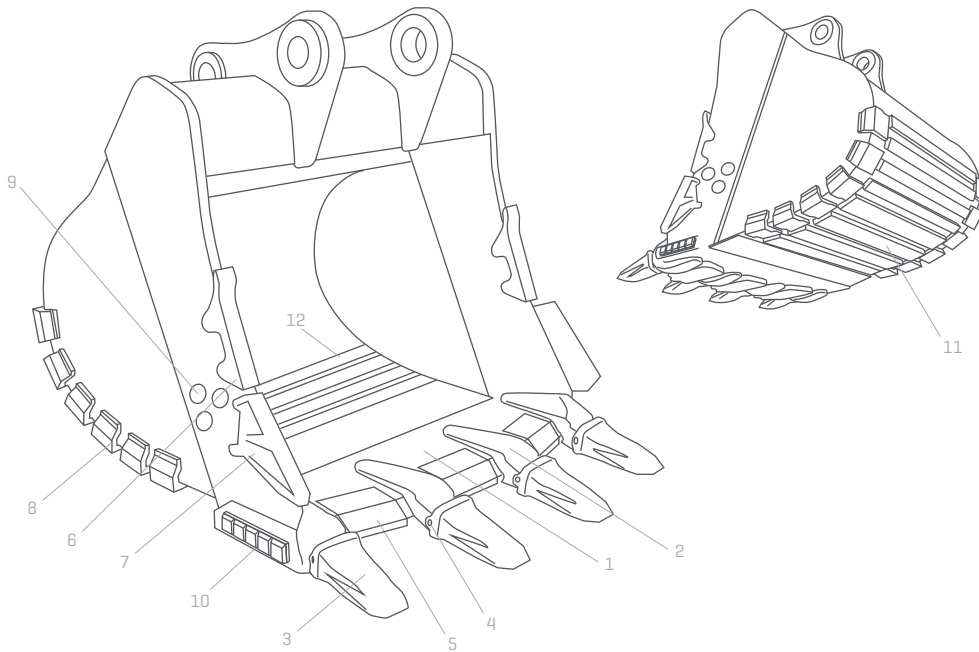

Lip Shape  
 Spade  
 Straight

Bucket Type  
 Rock  
 Heavy Duty  
 Standard

Application  
 \_\_\_\_\_

	Part No	Qty	Dimensions
1 Bucket lip [Length x width x thickness]			
2 Adapter			
3 Tips			
4 Pin			
Retainer / lock			
5 Lip Shroud (Spade: C/L/R)			
6 Leading edge protector OR			
<input type="checkbox"/> Weld on			
<input type="checkbox"/> Bolt on [center to center & thickness side bar]			
7 Side cutters [no. holes, hole sizes, leading edge thickness]			
8 Heel blocks			
9 Wear Button			
10 Chocky Bars			
11 Horizontal Bottom Wear Plates			
12 Wear strip [size]			
<input type="checkbox"/> Inside			
<input type="checkbox"/> Back			
<input type="checkbox"/> Side			