



TERRA

BLADE MEASUREMENT FORM

CUTTING EDGES, WEAR BLOCKS, GRADER BLADES & SEGMENTS

Indicate the type of countersink:

- opposite side as bevel
- same side as bevel
- both sides
- N/A

Indicate the type of profile needed:

- single bevel
- parallel bevel
- double bevel dozer
- double bevel loader
- square edge
- single bevel curved
- double bevel curved

Required information

Part number _____

Material type _____

Size & type of holes _____

No. of bolt holes _____ Bolt size _____

Date _____

Additional information

Customer _____

Machine type _____

Model no. _____

Terra Industries personnel _____

Please fill in all appropriate dimensions in the spaces provided

Enter hole spacing in spaces provided

Overall length:

Width:

Thickness:

Dimension:

Dimension:

Please fill in all appropriate dimensions in the spaces provided

Enter hole spacing in spaces provided

Overall length:

Width:

Thickness:

Dimension:

Dimension:

Dimension:

Additional information:



BLADE MEASUREMENT FORM

BUCKET LIP & HALF ARROWS

Indicate the type of countersink:

- opposite side as bevel
- same side as bevel
- both sides
- N/A
- opposite side as bevel
- no holes

Indicate the type of bucket lip profile needed:

- single bevel
- square edge

Indicate the type of half arrow profile needed:

- bolt on edge 19 x 203mm
- weld on edge 29 x 254mm
- with holes 40 x 254mm
- without holes

Required information

Part number _____
Material type _____
Size & type of holes _____
No. of bolt holes _____ Bolt size _____
Date _____

Additional information

Customer _____
Machine type _____
Model no. _____
Terra Industries personnel _____

Please fill in all appropriate dimensions in the spaces provided

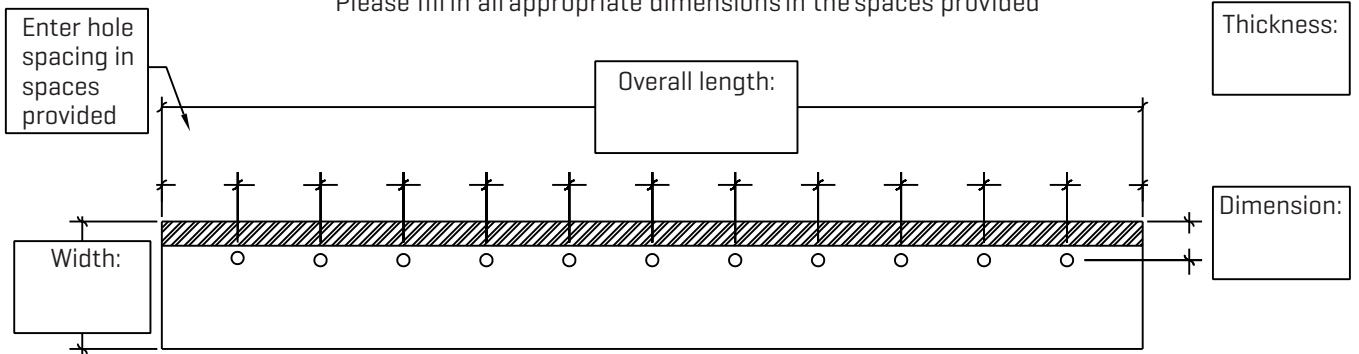

Indicate here if NO HOLES are required

Please fill in all appropriate dimensions in the spaces provided

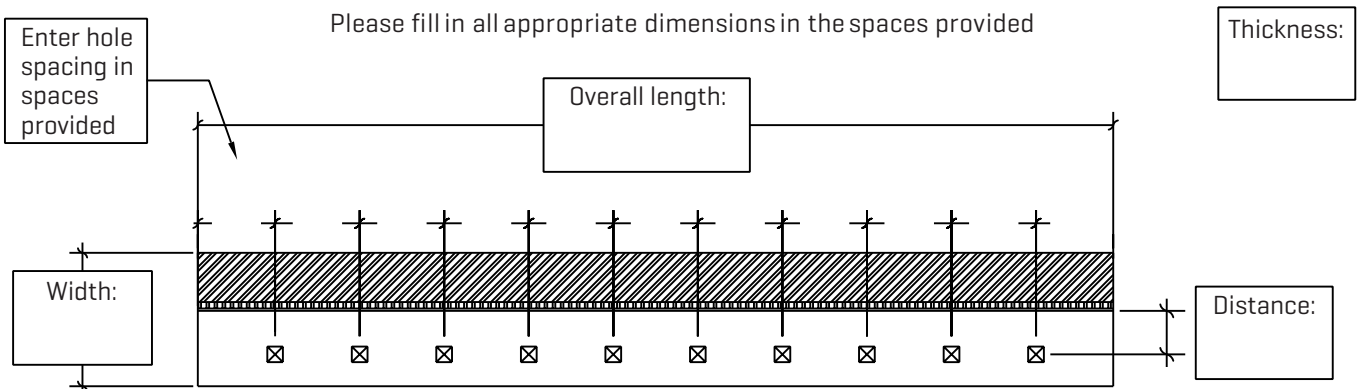



TERRA

BLADE MEASUREMENT FORM

END BITS

Indicate the type of countersink:

- opposite side as bevel
- same side as bevel
- both sides
- N/A

Indicate the type of profile needed:

- single bevel
- double bevel
- square edge

Required information

Part number _____

Material type _____

Size & type of holes _____

No. of bolt holes _____ Bolt size _____

Date _____

Additional information

Customer _____

Machine type _____

Model no. _____

Terra Industries personnel _____

Please fill in all appropriate dimensions in the spaces provided

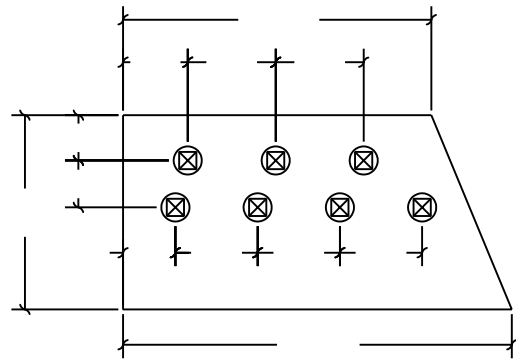
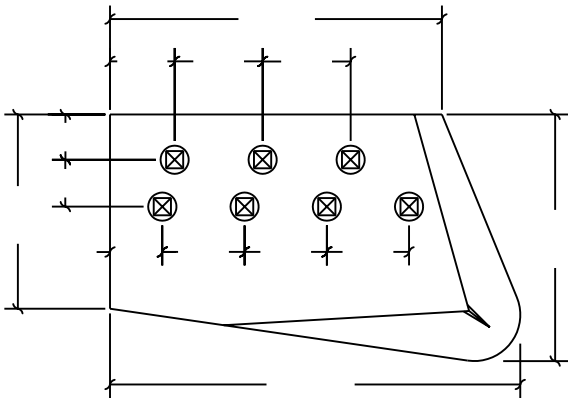

[Note: LEFT hand end bits shown, RIGHT hand will be opposite]

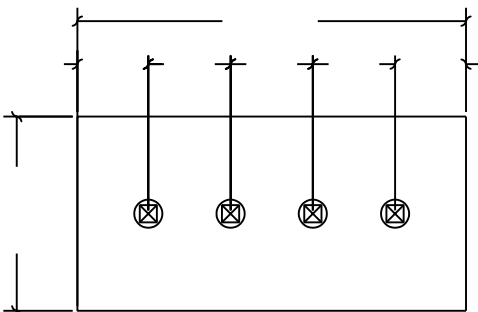

Additional information: